

plane is six inches. To the extent practicable, the left leg of the test dummy is in a vertical longitudinal plane.

S7.3.2 *For a test dummy in the outboard passenger positions.* The upper legs of each test dummy rest against the seat cushion to the extent permitted by placement of the feet. The initial distance between the outboard knee clevis flange surfaces is 11.5 inches. To the extent practicable, both legs of the test dummies in outboard passenger positions are in vertical longitudinal planes. Final adjustment to accommodate placement of feet in accordance with S7.4 for various passenger compartment configurations is permitted.

S7.4 *Feet.*

S7.4.1 *For a test dummy in the driver position.* The right foot of the test dummy rests on the undepressed accelerator with the heel resting as far forward as possible on the floorpan. The left foot is set perpendicular to the lower leg with the heel resting on the floorpan in the same lateral line as the right heel.

S7.4.2 *For a test dummy in the front outboard passenger position.* The feet of the test dummy are placed on the vehicle's toeboard with the heels resting on the floorpan as close as possible to the intersection of the toeboard and floorpan. If the feet cannot be placed flat on the toeboard, they are set perpendicular to the lower legs and placed as far forward as possible so that the heels rest on the floorpan.

S7.4.3 *For a test dummy in either of the rear outboard passenger positions.* The feet of the test dummy are placed flat on the floorpan and beneath the front seat as far as possible without front seat interference. If necessary, the distance between the knees can be changed in order to place the feet beneath the seat.

S8. *Phase-in of dynamic test and performance requirements.*

S8.1 [Reserved]

S8.2 [Reserved]

S8.3 *Passenger cars manufactured on or after September 1, 1995 and before September 1, 1996.*

S8.3.1 The number of passenger cars complying with the requirements of S3(c) shall be not less than 40 percent of:

(a) The average annual production of passenger cars manufactured on or after September 1, 1992, and before September 1, 1995, by each manufacturer, or

(b) The manufacturer's annual production of passenger cars during the period specified in S8.3.

S8.4 *Passenger cars produced by more than one manufacturer.*

S8.4.1 For the purposes of calculating average annual production of passenger cars for each manufacturer and the number of passenger cars manufactured by each manufacturer under S8.1, S8.2, and S8.3, a passenger car produced by more than one manufacturer shall be attributed to a single manufacturer as follows, subject to S8.4.2:

(a) A passenger car which is imported shall be attributed to the importer.

(b) A passenger car manufactured in the United States by more than one manufacturer, one of which also markets the vehicle, shall be attributed to the manufacturer which markets the vehicle.

S8.4.2 A passenger car produced by more than one manufacturer shall be attributed to any one of the vehicle's manufacturers specified by an express written contract, reported to the National Highway Traffic Safety Administration under 49 CFR part 586, between the manufacturer so specified and the manufacturer to which the vehicle would otherwise be attributed under S8.4.1.

[36 FR 22902, Dec. 2, 1971, as amended at 45 FR 17018, Mar. 17, 1980; 55 FR 45752, Oct. 30, 1990; 56 FR 27437, June 14, 1991; 56 FR 47011, Sept. 17, 1991; 57 FR 21615, May 21, 1992; 57 FR 30921 and 30922, July 13, 1992; 58 FR 14169, Mar. 16, 1993; 60 FR 38761, July 28, 1995; 60 FR 57839, Nov. 22, 1995; 63 FR 16140, Apr. 2, 1998]

§ 571.215 [Reserved]

§ 571.216 **Standard No. 216; Roof crush resistance.**

S1. *Scope.* This standard establishes strength requirements for the passenger compartment roof.

S2. *Purpose.* The purpose of this standard is to reduce deaths and injuries due to the crushing of the roof into the occupant compartment in rollover crashes.

S3. *Application.* This standard applies to passenger cars, and to multipurpose

passenger vehicles, trucks and buses with a GVWR of 2722 kilograms or less. However, it does not apply to—

- (a) School buses;
- (b) Vehicles that conform to the rollover test requirements (S5.3) of Standard No. 208 (§ 571.208) by means that require no action by vehicle occupants; or
- (c) Convertibles, except for optional compliance with the standard as an alternative to the rollover test requirements in S5.3 of Standard No. 208.

**S4. Definitions.**

*Altered roof* means the replacement roof on a motor vehicle whose original roof has been removed, in part or in total, and replaced by a roof that is higher than the original roof. The replacement roof on a motor vehicle whose original roof has been replaced, in whole or in part, by a roof that consists of glazing materials, such as those in T-tops and sunroofs, and is located at the level of the original roof, is not considered to be an altered roof.

*Raised roof* means, with respect to a roof which includes an area that protrudes above the surrounding exterior roof structure, that protruding area of the roof.

*Roof over the front seat area* means the portion of the roof, including windshield trim, forward of a transverse vertical plane passing through a point 162 mm rearward of the SgRP of the rearmost front outboard seating position.

*Windshield trim* means any molding, other than rubber molding and bonding adhesive, that is located over either the windshield glazing, the exterior roof surface or both.

**S5. Requirements.** When the test device described in S6 is used to apply a force to either side of the forward edge of a vehicle's roof in accordance with the procedures of S7, the lower surface of the test device must not move more than 127 millimeters. The applied force in Newtons is equal to 1.5 times the unloaded vehicle weight of the vehicle, measured in kilograms and multiplied by 9.8, but does not exceed 22,240 Newtons for passenger cars. Both the left and right front portions of the vehicle's roof structure must be capable of meeting the requirements. A particular vehicle need not meet further require-

ments after being tested at one location.

**S6. Test device.** The test device is a rigid unyielding block whose lower surface is a flat rectangle measuring 762 millimeters by 1,829 millimeters.

**S7. Test procedure.** Each vehicle must be capable of meeting the requirements of S5 when tested in accordance with the procedure in S7.1 through 7.6.

**S7.1** Place the sills or the chassis frame of the vehicle on a rigid horizontal surface, fix the vehicle rigidly in position, close all windows, close and lock all doors, and secure any convertible top or removable roof structure in place over the occupant compartment. Remove roof racks or other non-structural components.

**S7.2** Orient the test device as shown in Figure 1 of this section, so that—

- (a) Its longitudinal axis is at a forward angle (in side view) of 5 degrees below the horizontal, and is parallel to the vertical plane through the vehicle's longitudinal centerline;
- (b) Its transverse axis is at an outboard angle, in the front view projection, of 25 degrees below the horizontal.

**S7.3** Maintaining the orientation specified in S7.2—

- (a) Lower the test device until it initially makes contact with the roof of the vehicle.

- (b) Position the test device so that—

(1) The longitudinal centerline on its lower surface is on the initial point of contact, or on the center of the initial contact area, with the roof; and

(2) Except as specified in S7.4, the midpoint of the forward edge of the lower surface of the test device is within 10 mm of the transverse vertical plane 254 mm forward of the forwardmost point on the exterior surface of the roof, including windshield trim, that lies in the longitudinal vertical plane passing through the vehicle's longitudinal centerline.

**S7.4** If the vehicle being tested is a multipurpose passenger vehicle, truck, or bus that has a raised roof or altered roof, and the initial contact point of the test device is on the raised roof or altered roof to the rear of the roof over the front seat area, the plate is positioned so that the midpoint of the rearward edge of the lower surface of the test device is within 10 mm of the

transverse vertical plane located at the rear of the roof over the front seat area.

S7.5 Apply force so that the test device moves in a downward direction perpendicular to the lower surface of the test device at a rate of not more than 13 millimeters per second until reaching the force level specified in S5. Guide the test device so that throughout the test it moves, without rotation, in a straight line with its lower surface

oriented as specified in S7.2(a) and S7.2(b). Complete the test within 120 seconds.

S7.6 Measure the distance that the test device moved, i.e., the distance between the original location of the lower surface of the test device and its location as the force level specified in S5 is reached.

FIGURE 1 TO § 571.216

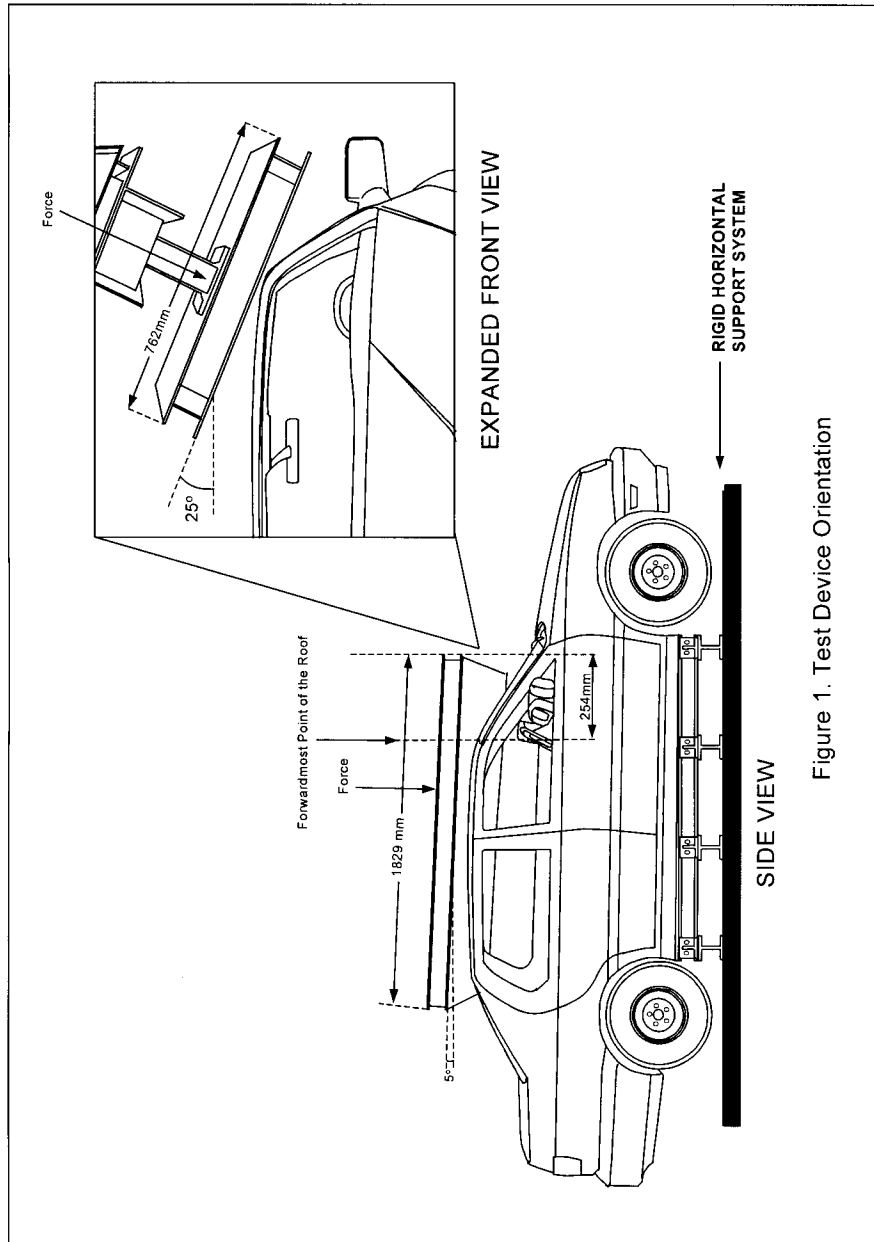

Figure 1. Test Device Orientation

[36 FR 23300, Dec. 8, 1971, as amended at 38 FR 21930, Aug. 14, 1973; 56 FR 15517, Apr. 17, 1991; 58 FR 5633, Jan. 22, 1993; 60 FR 13647, Mar. 14, 1995; 64 FR 22578, Apr. 27, 1999]

EFFECTIVE DATE NOTE: At 64 FR 22578, Apr. 27, 1999, § 571.216 was amended by revising S2, S4, S5, S6, and Figure 1; removing S6.1, S6.2, 6.3 and S6.4; and adding S7, S7.1, S7.2, S7.3,

S7.4, S7.5, S7.6, and a heading preceding Figure 1, effective Oct. 25, 1999. For the convenience of the user, the superseded text is set forth as follows:

**§ 571.216 Standard No. 216; Roof crush resistance.**

\* \* \* \* \*

S2. *Purpose.* The purpose of this standard is to reduce deaths and injuries due to the crushing of the roof into the passenger compartment in rollover accidents.

\* \* \* \* \*

S4. *Requirements.*

(a) *Passenger cars.* A test device as described in S5 shall not move more than 125 millimeters, measured in accordance with S6.4, when it is used to apply a force in newtons equal to 1½ times the unloaded vehicle weight of the vehicle, measured in kilograms and multiplied by 9.8 or 22,240 newtons, whichever is less, to either side of the forward edge of a vehicle's roof in accordance with the procedures of S6. Both the left and right front portions of the vehicle's roof structure shall be capable of meeting the requirements, but a particular vehicle need not meet further requirements after being tested at one location.

(b) *Multipurpose passenger vehicles, trucks and buses with a GVWR of 2,722 kilograms or less, manufactured on or after September 1, 1994.* For multipurpose passenger vehicles, trucks and buses with a GVWR of 2,722 kilograms or less, manufactured on or after September 1, 1994, a test device as described in S5 shall not move more than 125 millimeters, measured in accordance with S6.4, when it is used to apply a force in newtons equal to 1½ times the unloaded vehicle weight of the vehicle, measured in kilograms and multiplied by 9.8, to either side of the forward edge of a vehicle's roof in accordance with the procedures of S6. Both the left and right front portions of the vehicle's roof structure shall be capable of meeting the requirements, but a particular vehicle need not meet further requirements after being tested at one location.

S5. *Test device.* The test device is a rigid unyielding block with its lower surface formed as a flat rectangle 762 millimeters × 1829 millimeters.

S6. *Test procedure.* Each vehicle shall be capable of meeting the requirements of S4 when tested in accordance with the following procedure.

S6.1 Place the sills or the chassis frame of the vehicle on a rigid horizontal surface, fix the vehicle rigidly in position, close all windows, close and lock all doors, and secure any convertible top or removable roof structure in place over the passenger compartment.

S6.2 Orient the test device as shown in Figure 1, so that—

(a) Its longitudinal axis is at a forward angle (side view) of 5° below the horizontal, and is parallel to the vertical plane through the vehicle's longitudinal centerline;

(b) Its lateral axis is at a lateral outboard angle, in the front view projection, of 25° below the horizontal;

(c) Its lower surface is tangent to the surface of the vehicle; and

(d) The initial contact point, or center of the initial contact area, is on the longitudinal centerline of the lower surface of the test device and 254 millimeters from the forwardmost point of that centerline.

6.3 (a) *Passenger cars.* Apply force in a downward direction perpendicular to the lower surface of the test device at a rate of not more than 13 millimeters per second until reaching a force in newtons of 1½ times the unloaded vehicle weight of the tested vehicle, measured in kilograms and multiplied by 9.8 or 22,240 newtons, whichever is less. Complete the test within 120 seconds. Guide the test device so that throughout the test it moves, without rotation, in a straight line with its lower surface oriented as specified in S6.2(a) through S6.2(d).

(b) *Multipurpose passenger vehicles, trucks and buses with a GVWR of 2,722 kilograms or less, manufactured on or after September 1, 1994.* For multipurpose passenger vehicles, trucks and buses with a GVWR of 2,722 kilograms or less, manufactured on or after September 1, 1994, apply force in a downward direction perpendicular to the lower surface of the test device at a rate of not more than 13 millimeters per second until reaching a force in newtons of 1½ times the unloaded vehicle weight of the tested vehicle, measured in kilograms and multiplied by 9.8. Complete the test within 120 seconds. Guide the test device so that throughout the test it moves, without rotation, in a straight line with its lower surface oriented as specified in S6.2(a) through S6.2(d).

S6.4 Measure the distance that the test device moves, i.e., the distance between the original location of the lower surface of the test device and its location as the force level specified in S6.3 is reached.

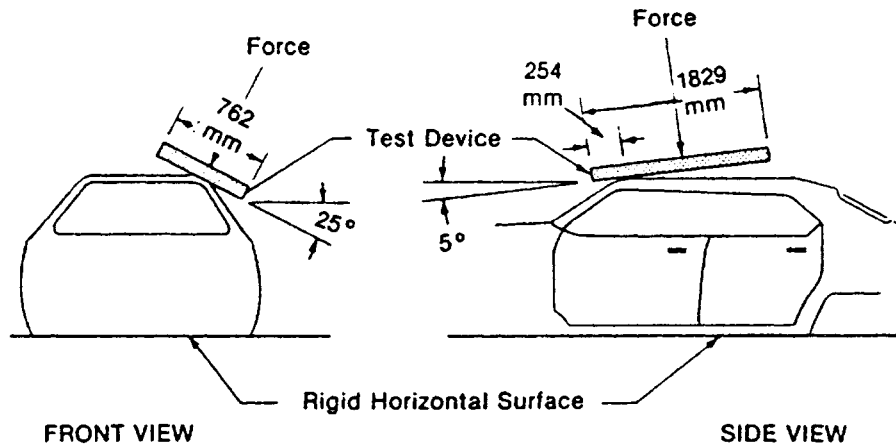

**Figure 1.—Test Device Location And Application To The Roof**

**§ 571.217 Standard No. 217; Bus emergency exits and window retention and release.**

S1. *Scope.* This standard establishes requirements for the retention of windows other than windshields in buses, and establishes operating forces, opening dimensions, and markings for bus emergency exits.

S2. *Purpose.* The purpose of this standard is to minimize the likelihood of occupants being thrown from the bus and to provide a means of readily accessible emergency egress.

S3. *Application.* This standard applies to buses, except buses manufactured for the purpose of transporting persons under physical restraint.

S4. *Definitions.* *Adjacent seat* means a designated seating position located so that some portion of its occupant space is not more than 10 inches from an emergency exit, for a distance of at least 15 inches measured horizontally and parallel to the exit.

*Daylight opening* means the maximum unobstructed opening of an emergency exit when viewed from a direction perpendicular to the plane of the opening.

*Mid-point of the passenger compartment* means any point on a vertical transverse plane bisecting the vehicle longi-

tudinal centerline that extends between the two vertical transverse planes which define the foremost and rearmost limits of the passenger compartment.

*Occupant space* means the space directly above the seat and footwell, bounded vertically by the ceiling and horizontally by the normally positioned seat back and the nearest obstruction of occupant motion in the direction the seat faces.

*Passenger compartment* means space within the school bus interior that is between a vertical transverse plane located 76 centimeters in front of the forwardmost passenger seating reference point and a vertical transverse plane tangent to the rear interior wall of the bus at the vehicle centerline.

*Post and roof bow panel space* means the area between two adjacent post and roof bows.

*Push-out window* means a vehicle window designed to open outward to provide for emergency egress.

*Sliding window* means a bus window designed to open by moving vertically or horizontally to provide emergency egress.

S5. *Requirements.*